

$[(\text{CH}_3)_2\text{HN}]_2\text{BH}_2\text{PF}_6$. In a similar manner equivalent amounts of dimethylamine-borane, iodine, and dimethylamine were allowed to react to give a 95% yield of crude iodide salt. Conversion to the hexafluorophosphate salt in dilute acid gave a 30% yield, mp 100–104°. Concentration of the filtrate gave another 37% of the cation, mp 87–93°. Repeated precipitation from methylene chloride with petroleum ether gave a sample melting at 102–104°.

Anal. Calcd for $\text{C}_4\text{H}_{16}\text{BF}_6\text{N}_2\text{P}$: C, 19.38; H, 6.50; N, 11.30. Found: C, 19.37; H, 6.59; N, 10.97.

The Reaction of Pyridine-Monoiodoborane with Dimethylamine. A sample of 1.65 g (17.7 mmol) of pyridine-borane was dissolved in 30 ml of benzene and 2.10 g (8.3 mmol) of I_2 added slowly. The reaction mixture was stirred for 10 min and then 16.8 mmol of dimethylamine in 34 ml of benzene was added. After stirring for another hour the benzene layer was decanted off and the remaining oil dried under vacuum giving 4.27 g of product. This was dissolved in 10 ml of 0.1 M HCl and treated with 18.7 mmol of ammonium hexafluorophosphate. The precipitate was filtered, rinsed with water and ether, and dried under vacuum to give 2.37 g (7.5 mmol) of $(\text{C}_5\text{H}_5\text{N})_2\text{BH}_2^+\text{PF}_6^-$, mp 103–109° (lit.¹⁰ 116°). Except for a small impurity the nmr spectrum was identical with that of an authentic sample. The washings were evaporated under reduced pressure to give 0.42 g of an oil. The nmr spectrum showed this oil to be about half $[(\text{CH}_3)_2\text{HN}]_2\text{BH}_2\text{PF}_6$ and part $(\text{C}_5\text{H}_5\text{N})_2\text{BH}_2\text{PF}_6$. The filtrate was evaporated under reduced pressure and the resulting solid extracted with dichloromethane. Evaporation of this solution gave 1.61 g of an oil which the nmr spectrum showed to be about 90% $[(\text{CH}_3)_2\text{HN}]_2\text{BH}_2\text{PF}_6$. Thus, of the expected 16.5 mmol of boron cation, 7.5 mmol (46%) can be accounted for as $(\text{C}_5\text{H}_5\text{N})_2\text{BH}_2\text{PF}_6$ and 6.6 mmol (40%) as $[(\text{CH}_3)_2\text{HN}]_2\text{BH}_2\text{PF}_6$. There was no evidence for the mixed cation, $(\text{CH}_3)_2\text{HN}(\text{C}_5\text{H}_5\text{N})\text{BH}_2\text{PF}_6$.

$[(\text{CH}_3)_2\text{NBH}_2]_2$. To 3.00 g (50.9 mmol) of resublimed $(\text{CH}_3)_2\text{HNBH}_3$ in 15 ml of dichloromethane and 15 ml (108 mmol) of triethylamine was added 12.7 g (50.0 mmol) of solid iodine in small portions over 15 min. The stirred solution was cooled in an ice bath. After stirring for another 10 min the reaction vessel was attached to the vacuum line and cooled to -45° ; the more volatile components were removed. The remaining solid was warmed to 25° and the $[(\text{CH}_3)_2\text{NBH}_2]_2$ removed and purified by trap to trap fractionation. The product, 1.28 g (12.4 mmol), was characterized by the nmr spectrum, comparison with the published infrared spectrum, and vapor pressure of 8 mm at 20° (8 mm reported¹¹).

(10) G. E. Ryschkewitsch, *J. Amer. Chem. Soc.*, **89**, 3145 (1967).

Distillation of Dimethylaminoborane and Pyridine from I and Tri-*n*-butylamine. A sample of 0.50 g of I was dissolved in 2.0 ml of tri-*n*-butylamine (dried over molecular sieves) and 50 ml of nitrobenzene. After several minutes the slight gas evolution stopped. The solution was held at 25° and fractionated through -15° and -78° traps for 5 min. The contents of the traps were discarded and the process repeated for 10 min. Except for the appearance of a few small extra bands the infrared spectrum of the -78° trap was a simple summation of the spectra of dimethylaminoborane and pyridine.

Preparation of I from Dimethylaminoborane and Pyridinium Hexafluorophosphate. A sample of 0.058 g (1.02 mmol) of dimethylaminoborane dimer and 0.180 g (0.80 mmol) of pyridinium hexafluorophosphate was heated at 70° in acetonitrile for 1.5 hr. The solvent was removed and the remaining oil recrystallized from 3 M HCl to give 0.10 g (0.35 mmol) of I, mp 84–86°.

Attempts to Isolate $(\text{CH}_3)_2\text{N}(\text{C}_5\text{H}_5\text{N})\text{BH}_2$. The reaction of I with NaBH_4 in acetonitrile gave pyridine-borane and dimethylamine-borane, identified by the nmr spectrum. A slight evolution of a gas was observed.¹² The reaction of I with LiAlH_4 gave dimethylamine-borane but no pyridine-borane, as shown by nmr.

The nmr spectrum of the reaction mixture of the iodide salt of I with a deficiency of *n*-butyllithium showed apparent doublets in the methyl region ($J = 5.5$ Hz) and absorptions in the pyridine region besides the peaks due to unreacted I. The presence of II is thus denied, since exchange would collapse the doublets.

A solution of I in CH_2Cl_2 was allowed to react with solid, anhydrous K_2CO_3 . The infrared and nmr spectra could be interpreted as showing the presence of II along with several other major components. However, changes in the nmr spectrum upon the addition of HCl did not indicate the expected production of I from II.

In another approach an acetonitrile solution of dimethylaminoborane and pyridine was heated. The changes in the nmr spectrum showed several reactions occurring. The addition of HCl produced no I.

Acknowledgment. Partial support of this work under National Institutes of Health Grant GM 13650 is gratefully acknowledged.

(11) E. Wiberg, A. Bolz, and P. Buchheit, *Z. Anorg. Allg. Chem.*, **256**, 285 (1948).

(12) A similar behavior reported for the bis-*n*-butylamine boron cation: H. Noth, H. Beyer, and H. Vetter, *Chem. Ber.*, **97**, 110 (1964).

The Preparation of Borane in High Absolute Yield from Borane Carbonyl¹

G. W. Mappes and T. P. Fehlner

Contribution from the Department of Chemistry, University of Notre Dame, Notre Dame, Indiana 46556. Received August 30, 1969

Abstract: Borane, BH_3 , has been produced in yields of 60% from borane carbonyl, BH_3CO . BH_3CO diluted to a high degree in an inert carrier gas is thermally decomposed in a tubular fast flow reactor. Analysis of the products is accomplished utilizing a mass spectrometer with molecular beam sampling. An absolute sensitivity for borane has been obtained by a kinetic method and streams containing up to 50 mTorr of BH_3 have been produced. Purities of up to 84% based on total boron hydrides have been achieved.

The chemical and physical nature of the borane species, BH_3 , has been the subject of considerable interest for many years. It appears that borane, in the absence of any form of coordination, may be viewed as a small planar molecule with a singlet ground state.

(1) Presented in part at the 157th National Meeting of the American Chemical Society, Minneapolis, Minn., April 1969, Abstract No. INOR 33; abstracted from the Ph.D. Thesis of G. W. Mappes.

It has an empty p orbital which, in contrast to that of BF_3 , is not involved in π bonding. The electronic structure of BH_3 is essentially different from that of other reactive species, e.g., free radicals. Thus experimental information on the nature of this species serves to illuminate a new facet of chemistry.

The direct identification of small quantities of BH_3 in the gas phase by a number of groups^{2–10} was the

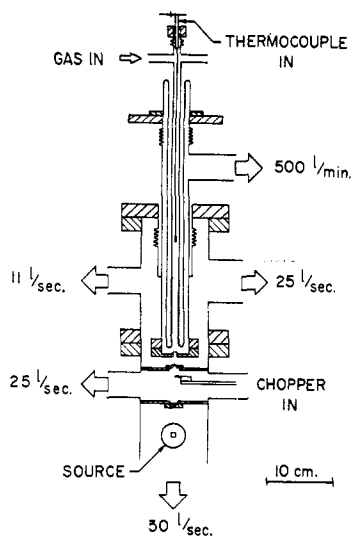

Figure 1. Schematic drawing of the fast flow reactor and molecular beam sampling system.

first step in characterizing the nature of this species. However, many physical and chemical experiments that the authors would like to perform require much more than trace amounts of the species under investigation. Consequently, efficient sources of BH_3 have been sought, and one successful approach is reported below.

This approach is based on the thermal decomposition of a weakly bound complex containing BH_3 . The first candidate considered was BH_3CO , as the original study⁴ of the low pressure pyrolysis of this compound showed the production of BH_3 . A later, more complete, study⁹ showed that the yield of BH_3 was small due to the destruction of BH_3 on the surface. These experiments and others¹¹ suggested that a higher pressure flow system with large dilution with an inert gas would yield substantial concentrations of BH_3 . Such a system is described below. It should be noted here that this system was designed both to produce BH_3 and to characterize certain specific chemical properties. It is quite probable that for other types of experiments, simplifying modifications of this system can easily be devised.

Experimental Section

Reactor. The reactor and associated equipment are illustrated in Figure 1. The reactor was fabricated from 10-mm quartz tubing with a 1-mm wall and is similar in design to one described pre-

(2) T. P. Fehlner and W. S. Koski, *J. Amer. Chem. Soc.*, **86**, 2733 (1964).

(3) E. J. Sinke, G. A. Pressley, Jr., A. B. Baylis, and F. E. Stafford, *J. Chem. Phys.*, **41**, 2207 (1964).

(4) T. P. Fehlner and W. S. Koski, *J. Amer. Chem. Soc.*, **87**, 409 (1965).

(5) A. B. Baylis, G. A. Pressley, Jr., and F. E. Stafford, *ibid.*, **88**, 2428 (1966).

(6) J. H. Wilson and H. A. McGee, *J. Chem. Phys.*, **46**, 1444 (1967).

(7) H. A. McGee, Jr., Abstracts, 157th National Meeting of the American Chemical Society, Minneapolis, Minn., April 1969, No. PHYS 61; P. S. Ganguli and H. A. McGee, Jr., *J. Chem. Phys.*, **50**, 4658 (1969).

(8) O. Herstad, G. A. Pressley, Jr., and F. E. Stafford, *J. Phys. Chem.*, in press.

(9) T. P. Fehlner and G. W. Mappes, *ibid.*, **73**, 873 (1969).

(10) S. J. Steck, G. A. Pressley, and F. E. Stafford, *ibid.*, **73**, 1000 (1969).

(11) T. P. Fehlner and S. F. Fridmann, Abstracts, Third Great Lakes Regional Meeting of the American Chemical Society, DeKalb, Ill., June 1969, p 44.

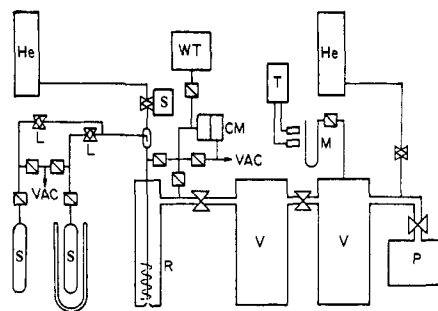

Figure 2. Schematic drawing of the flow system. CM refers to the differential capacitance manometer, while S refers to the servo-driven leak. WT denotes the Wallace-Tiernan Bourdon gauge. M and T are a manometer and photocell timer, respectively, and are used to measure the pumping speed of the 500 l./min pump, P. R is the reactor and V is a 300-l. tank. The tubing connecting the reactor and pump, P, is a nominal 2-in. diameter. He refers to the carrier gas supply and S is the sample bulb. L is a variable leak. The entire system was constructed with metal valves and grease-free glass stopcocks.

viously.¹² This reactor is wound with 20 identical heating coils consisting of 5 turns of 28-gauge chromel "A" wire space with 24-gauge wire. After removal of the spacing wire, Ceramabond 503 cement was applied to just cover the coils. Drying at 250°F for several hours was followed by curing at 1000°F for several minutes. Copper leads were silver soldered to each coil, a 25-mm o.d. quartz tube was fitted over the reactor and lead wires, and a dewar seal was made at the end of the reactor so that the lead wires would not have to be connected to a power source through vacuum seals. The two concentric reactor tubes were then connected to a mounting flange by means of quartz to Pyrex seals and Pyrex to metal seals. The mounting flange provided a vacuum seal to the outer reactor jacket and held the concentric reactor tubes centered in the outer jacket. The carrier gas then flowed through the 10-mm quartz tube and the reactor proper, and was pumped away through the annular space between the 25-mm quartz tube and the outer jacket. The outer jacket of the reactor was fabricated from stainless steel and included a number of bellows to allow alignment of the molecular beam system.

A temperature of the carrier gas along the center axis of the reactor was measured with a scanning thermocouple probe. The thermocouple was constructed of 0.005-in. chromel and constantan (Omega Engineering) wire mounted in a 1/16-in. o.d. two-hole ceramic rod. Entry into the vacuum system was by means of a double "O" ring vacuum seal which allowed scanning during actual operation of the system. Scanning was accomplished utilizing a synchronous motor and the lead screw of a small lathe. The scan rate was 10 mm per min. The main objective of the scanning thermocouple was to measure the reproducibility of the temperature profiles along the cylindrical axis of the reactor. It was then an easy, though tedious, task to make corrections in the profiles required by changes in flow velocity, gas composition, and pressure. The temperatures reported are those measured with this system. It is possible that the actual temperature of the gas is slightly different from that measured. However, no corrections have been attempted, as the work reported here is preparative in nature, and the reactions of BH_3 that the authors intend to study have small temperature coefficients.

The flow system is illustrated in Figure 2. This system was designed to give linear flow velocities of up to 10^8 cm/sec. The carrier gas was metered into the flow system with a servo-driven leak controlled by a differential capacitance manometer. The reactor is connected to the 500-l./min mechanical pump through two 300-l. tanks. These tanks serve to dampen fluctuations in the pumping speed of the pump and allow the accurate measurement of the pumping speed. Pumping speed changes at the reactor were accomplished by adding carrier gas between the last tank and the pump. This was found to be more satisfactory than changing the conductance of a large valve. Under typical conditions of the work reported here, the Reynolds number of the gas in the reactor was below the minimum value for turbulent flow in a smooth

(12) I. P. Fisher, J. B. Homer, B. Roberts, and F. P. Lossing, *Can. J. Chem.*, **44**, 2205 (1966).

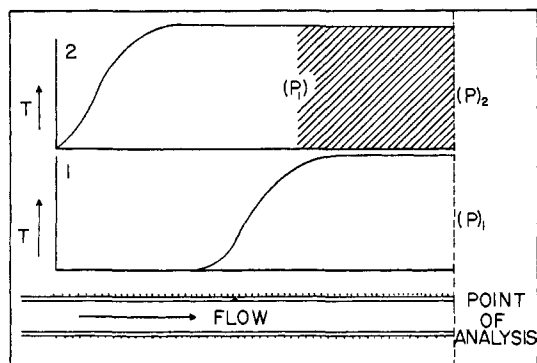

Figure 3. Schematic drawing of the reactor showing typical temperature profiles. Temperature profiles were measured along the cylindrical axis of the reactor. (P) refers to a measured product distribution.

tube.¹³ The presence of the thermocouple probe almost assures that the flow in the reactor is turbulent in nature. Therefore the reactor may be treated as a case of plug flow.

Analysis. The gases in the reactor were sampled through a ca. 2×10^{-2} mm nearly round hole in a thin-walled quartz cone. The sampling orifice was situated 5 mm downstream from the last reactor coil, as shown in Figure 1. For typical flow velocities used here the minimum sampling time was ca. 5×10^{-5} sec. These orifices were constructed as has been described previously¹⁴ except that an air-abrasive tool was used to thin the apex of the quartz cone. The diameters of the orifices used were small enough so that the flow through the orifice was mainly molecular in nature. The efflux of the sampling orifice was collimated into a molecular beam using a three-stage differentially pumped system. The molecular beam is crossed with an electron beam and the resulting ions are analyzed in a 60° magnetic sector instrument with electron multiplier detection. The molecular beam is mechanically modulated at 160 Hz, and only the output of the mass spectrometer, which has the same frequency and the proper phase shift from the modulating device, is reported here. More details of the modulated molecular beam detection system may be found elsewhere.¹⁵ The use of such a system is very convenient in this type of study. First, all steady state background is eliminated (a particular convenience here where one of the products, CO, appears at m/e 28). It eliminates interference from processes taking place in the ion source (such as pyrolysis) which confuse the analysis. Finally, as this system discriminates very strongly against molecules which have suffered collisions either with the wall or other species, it "preserves" the composition of the gases sampled from the reactor for analysis.

With a reactor pressure of 5 Torr, the pressure in the first stage of the beam system was 2×10^{-5} Torr, 2×10^{-6} in the second, and 2×10^{-8} in the mass spectrometer chamber. The calculated beam intensity at the ion source for a pressure of 10^{-2} Torr of butane in the reactor is 6×10^8 molecules/sec. For typical operating conditions, the dc output of the mass spectrometer for such a beam intensity was 6×10^{-12} A for m/e 43. Because of the low intensities involved and because of the high rate of reactant consumption (*vide infra*), the spectrometer was focused individually on each ion of interest for several different reactant concentrations in the carrier gas. After the complete identification of products, only the intensities of the m/e 40, 28, 26, and 13 ion peaks, representing BH_3CO , CO, B_2H_6 , and BH_3 , respectively, were measured.

Calibration of the reactor-mass spectrometer system for the stable gases C_4H_{10} , BH_3CO , B_2H_6 , CO, and H_2 was carried out in the conventional way. Various pressures (measured with a Wallace-Tiernan pressure gauge) of a given gas were admitted to the reactor and the pertinent ion intensities measured. These data yielded the relative sensitivities for the gases. The absolute sensitivity of C_4H_{10} was then measured under the flow conditions (5 Torr total pressure, 95% helium, 5% C_4H_{10}) by measuring the pressure de-

(13) S. Dushman and J. M. Lafferty, Eds., "Scientific Foundations of Vacuum Technique," 2nd ed, John Wiley and Sons, Inc., New York, N. Y., 1962, p 85.

(14) F. P. Lossing and A. W. Tickner, *J. Chem. Phys.*, **20**, 907 (1952).

(15) T. P. Fehlner, *J. Amer. Chem. Soc.*, **90**, 4817 (1968); S. N. Foner, "Advances in Atomic and Molecular Physics," D. R. Bates, Ed., Academic Press, New York, N. Y., 1966, p 385.

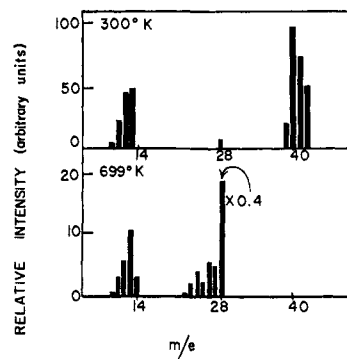

Figure 4. Mass spectra at two reactor temperatures. The upper spectrum is that of the reactant BH_3CO . The lower spectrum is that of the products CO, B_2H_6 , and BH_3 . Note that only the m/e 28 ion intensity has been multiplied by 0.4. See also footnote 16.

crease per unit time in a large bulb of known volume. The butane sensitivity was also measured in the same manner but at higher temperatures.

During an experiment the reactant, BH_3CO , was injected into the helium stream at a given mass flow by opening a variable leak (Granville-Phillips) to a precalibrated setting. The reactant reservoir was maintained at a constant temperature of 175°K (vapor pressure of 90 Torr) and the leak settings were shown to be reproducible to within 4%. The maximum partial pressure of reactant used was 4.5% of the total pressure. This corresponds to a mass flow of 0.5 Torr l./sec at a typical total reactor pressure of 5 Torr.

Preparations. Borane carbonyl was prepared and purified as described previously.⁹ About 0.04 mol of BH_3CO is required for a typical experimental run. The purity of the borane carbonyl was determined from its mass spectrum. The borane carbonyl used here was better than 95% pure, the major impurity being diborane. The diborane used was also prepared and purified as described previously.⁹ The CO, C_4H_{10} , H_2 , and He were obtained as compressed gases and were used without further purification.

Results

Identification of Products. Decomposition of BH_3CO was accomplished by adjusting the power to the heating coils to produce a temperature profile along the axis of the reactor similar to that shown in part 1 of Figure 3. The decomposition time and temperature were adjusted to decompose between 90 and 95% of the BH_3CO . Typical values were 0.4 msec at 700°K . The stable gaseous products were identified from their mass spectra. Mass spectra at two decomposition temperatures are shown in Figure 4.¹⁶ The upper portion of Figure 4 shows the mass spectrum of the reactant BH_3CO , while the lower portion shows the spectra of the decomposition products. The production of CO is easily identifiable from the large increase in the m/e 28 ion intensity. Diborane is recognized by its characteristic fragmentation pattern in the m/e 22-27 region. The intense ions in the m/e 11-14 region are discussed below. Higher boron hydrides were sought, but no evidence for their presence in concentrations greater than 5% of the BH_3CO decomposed was found. Hydrogen gas was also sought, but was not present in concentrations greater than 20% of the BH_3CO decomposed. This upper limit is poor because of a low sensitivity for H_2 and a very high H_2^+ background, which appears as noise in the detection system. A solid product was observed as a deposit on the reactor walls. The deposit showed the following analysis:

(16) The ion intensity at each m/e value is optimized; consequently, the relative intensities obtained here may not be exactly the same as those taken in a conventional instrument.

97.4% boron, <1% carbon, and <1% hydrogen. The production of solid boron is taken as positive evidence that some H₂ is being produced.

With the sensitivities for the stable gases, a partial mass balance for the stable gaseous products may be determined. In a typical experiment at 700°K the following are found: 10 units of boron lost, 1.5 found; 10 units of hydrogen lost, 2.0 found. We are not able to measure the boron deposited in the reactor. However, from the upper limit on the H₂ concentration it is evident that for 10 units of hydrogen lost at least 6 are unaccounted for. This implies the existence of another product or products.

An examination of the lower portion of Figure 4 along with the characteristic fragmentation patterns of BH₃CO and B₂H₆ shows that the large ion peaks in the *m/e* 11–14 region cannot be due to fragmentation of either diborane or borane carbonyl. The data for a typical experiment are shown in a quantitative fashion in Table I. The first column contains the uncorrected

Table I. Mass Spectrum of Borane

| <i>m/e</i> | In- ten- sity | Cor for frag | Strip ¹⁰ B | Ion | Relative intensity | |
|------------|---------------------|--------------------|--------------------------|------------------------------|---------------------------|-------------------|
| | | | | | This work ^a | Lit. ^b |
| 14 | 11 | 8.9 | 8.9 | BH ₃ ⁺ | 30 | 31 |
| 13 | 38 | 35.2 | 33.0 | BH ₂ ⁺ | 100 | 100 |
| 12 | 19 | 12.1 | 3.9 | BH ⁺ | 18 | 16 |
| 11 | 11 | 6.2 | 5.2 | B ⁺ | 8 | 8 |

^a 70 eV, average of four runs.

intensities for the *m/e* 11–14 ions, and in the second column are values corrected by subtracting out the small contribution to these ion intensities due to fragmentation of the B₂H₆, BH₃CO, and CO present. The room temperature fragmentation patterns were used as there is no evidence that the fragmentation patterns change significantly at the reaction temperature used. In the third column the contribution of ¹⁰B-containing species is stripped out, so that these relative intensities may be compared with those previously reported for ¹⁰BH₃.⁵ As Table I shows, the comparison is good and, consequently, the authors confidently attribute the ion peaks in the *m/e* 11–14 region to the borane molecule. We wish to emphasize that, simply on the basis of the relative ion intensities measured, borane is the major boron hydride species present.

Sensitivity for Borane. Sensitivities, *i.e.*, relationships between ion current for a given ion and the concentration of the neutral species in the reactor which produces that ion, are easily obtained for stable gases. For unstable species an indirect method must be employed. The simplest way is to employ the mass balance of the reactant and products. In the present case, however, this was prevented with the boron balance due to the deposition of solid boron, and with the hydrogen balance due to inability to accurately measure the small concentrations of H₂. As noted below, however, the mass balance does allow limits on the sensitivity to be established. The indirect method used here might be called a kinetic method. The description of this method follows.

The product distribution, (P)₁, for profile 1 in Figure 3 is determined as described above. The reaction

time is then increased by setting up profile 2 in Figure 3, and the product distribution, (P)₂, is measured. As the leading edges of the profiles are made identical, the difference in these two product distributions is attributed to reaction in the shaded zone of profile 2. The unshaded portion of profile 2 is called the decomposition zone, while the shaded part is called the recombination zone. The products of the decomposition zone are the reactants of the recombination zone. These are B₂H₆, BH₃, and small amounts of BH₃CO, CO, and H₂. The identity of the products of the recombination zone are the same, although the relative and absolute amounts have changed. By varying the borane carbonyl mass flow it has been shown that the loss of BH₃CO in the decomposition zone and loss of BH₃ in the recombination zone is *ca.* 80% or better, first-order in BH₃CO and BH₃, respectively. If *k*_d and *k*₁ are the first-order rate constants for the loss of BH₃CO and BH₃, respectively, then the following equation¹⁷ may be written

$$(\text{BH}_3)_1 = k_d(\text{BH}_3\text{CO})_0[e^{-k_d t} - e^{-k_1 t}]/[k_1 - k_d]$$

provided that it is assumed that every molecule of borane carbonyl that decomposes produces one BH₃. This assumption is discussed below. Here (BH₃)₁ refers to the borane concentration measured with profile 1 and (BH₃CO)₀ is the borane carbonyl concentration before decomposition. The rate constants, *k*_d and *k*₁, may be simply calculated from the loss of BH₃CO in profile 1 and the loss of BH₃ in the shaded zone of profile 2. As the sensitivity of BH₃CO is known, the equation above may be used to calculate a sensitivity for BH₃. It is found that *S*_{BH₃}/*S*_{BH₃CO} = 0.7 ± 0.2, where *S* is in units of ion current per unit pressure, and the *m/e* 13 and 40 ions were used to measure the concentration of BH₃ and BH₂CO, respectively.

The assumption that every molecule of BH₃CO decomposed produces one BH₃ molecule was checked in the following manner. The diborane produced in the recombination zone results from borane, as this is the major reactant present. Consequently, the production of B₂H₆ in this zone places a lower limit on the loss of BH₃ and, therefore, an upper limit on the sensitivity of BH₃. If there were any parallel paths not resulting in the production of BH₃ for the loss of BH₃CO in the decomposition zone, then the real sensitivity of BH₃ would be larger than that calculated from the equation above, *i.e.*, the *k*_d calculated from profile 1 would be too large. It was found that the upper limit on the sensitivity of BH₃ determined from B₂H₆ production in the recombination zone decreases with decreasing temperature of the recombination zone. For a recombination zone temperature of 545°K the upper limit of the sensitivity is equal, within experimental error, to the kinetic sensitivity determined above. Therefore, the assumption that each molecule of BH₃CO produces one BH₃ is valid. This conclusion may be expressed in a slightly different fashion in terms of a mass balance for the reaction 2BH₃ → B₂H₆ in the recombination zone at 545°K. For three experiments an average mass balance is 269 units of BH₃ going to 136 units of B₂H₆, where the units are arbitrary and have been corrected

(17) A. A. Frost and R. G. Pearson, "Kinetics and Mechanism," 2nd ed, John Wiley and Sons, Inc., New York, N. Y., 1965, p 167.

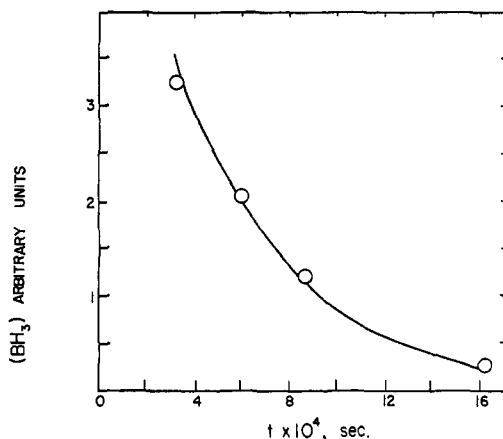

Figure 5. A plot of the yield of BH_3 as a function of residence time at 700°K . The solid curve corresponds to an exponential decay with a half-life of 0.33 msec.

for the relative sensitivities of BH_3 and B_2H_6 . From the stoichiometry discussed above, a lower limit on the sensitivity of BH_3 may be established. If it is assumed that all the BH_3CO initially gives BH_3 and CO , *i.e.*, no boron or hydrogen production, then a lower limit of $S_{\text{BH}_3}/S_{\text{BH}_3\text{CO}} \geq 0.4$ is obtained.

Yield of Borane. With a sensitivity for BH_3 , the absolute yield of this reactor may be calculated. For a decomposition temperature of 708°K and a reaction time of 0.33 msec the highest yield of BH_3 was 61%, while the average yield was 52%. Yield is defined here as the ratio of the partial pressure of BH_3 in the reactor to the partial pressure of BH_3CO decomposed. Neglecting the carrier gas and CO , the gas composition was 67% BH_3 , 8% BH_3CO , 5% B_2H_6 , and 20% H_2 (the H_2 was obtained by a mass balance). We have been able to prepare partial pressures of BH_3 as high as 50 mTorr in this fashion. This is a better net yield by one or two orders of magnitude than those suggested or reported previously.²⁻¹⁰ Considering only the boron hydrides, the borane produced is 84% pure.

Figure 5 shows a plot of the relative concentration of BH_3 produced as a function of decomposition time at 700°K . The decay of BH_3 is roughly first order and the solid line represents a first-order fit of the data. The half-life of the first order decay is 0.33 msec. This

plot emphasizes the fact that unless the decomposition time for BH_3CO is the same order of magnitude as the half-life of BH_3 at the decomposition temperature, it is impossible to produce any appreciable yield of BH_3 . It is interesting to note here that for a BH_3CO decomposition time which is equal to the half-life of the BH_3 , a yield of *ca.* 50% would be expected. As will be recalled, the average yield for a reaction time of 0.33 msec was 52%.

Discussion

The concentrations of BH_3 produced in the manner described from BH_3CO are sufficient for the examination of some of the fast reactions of this species. The range of rate constants available for measurement is limited by the concentration of BH_3 . It is easily seen from Figure 5 that only the very fast reactions of this species are available for examination. The authors are presently engaged in a study of the self-association of BH_3 and the association of BH_3 with electron pair donors. In the latter case, the added reagent is stable and can be added at fairly high concentrations. Consequently the range of rate constants accessible is from 10^7 to 10^{11} l./mole sec. The results of these studies will be presented elsewhere.¹⁸

It is very possible that this source of BH_3 could be used for other types of physical experiments. One likely example is a matrix isolation spectroscopic examination of BH_3 . The major modification necessary in the experimental procedure would be the substitution of an inert gas with a higher boiling point for the helium carrier gas. This type of carrier is not suitable for the kinetic studies due to distortion of the temperature profiles. Such considerations would carry little weight for a matrix study. It might also be pointed out that the present system was limited to relatively low total pressures. It appears that it would be quite feasible to double or triple the total pressure in other systems, with a similar increase in the total BH_3 concentration.

Acknowledgments. This work was supported by a National Science Foundation Grant, GP-6820. G. M. acknowledges his support as a National Science Foundation Predoctoral Fellow.

(18) Presented at the 158th National Meeting of the American Chemical Society, New York, N. Y., Sept 1969, Abstract No. PHYS 71.